

ICBDF36450G/S/P

FEATURES

Product availability pending in country approval

Wolf's patented gas dual-stacked, sealed burner design provides precise high-to-low temperature control and a spark ignition system that reignites the burner automatically

Wolf's Dual VertiFlow™ convection system provides reliably even heat, reduces hot and cold spots, and enables consistent multi-rack cooking

Gourmet Mode features nearly 50 presets that automatically control the oven to ensure delicious results

The redesigned 15,000 Btu teppanyaki (griddle) features even, precise heat, handling breakfast with equal finesse as seared burgers and stir-fried vegetables

Four dual-stacked burners produce up to 20,000 Btu for fast boils and intense sears and 300 Btu for true simmers and worry-free melts

Ten cooking modes, including Bake, Broil, Convection, Convection Roast, Dehydrate, Gourmet, Proof, Roast, Stone, and Warm, were developed by Wolf chefs to maximize the performance of your oven

For improved temperature control and safety, the spark ignition system reignites burners automatically

The full-color touch screen is intuitive and easy to read, discreetly hiding away when not in use

LED backlit control knobs illuminate when in use, indicating which burners are active

The oven offers self-clean, delayed start, timed cook, and Sabbath features

The temperature probe alerts you when your dish has reached the desired temperature

Create a cohesive look in your kitchen with the range's stainless steel construction, pro style handles, and choice of iconic red, black, or brushed stainless knobs

ACCESSORIES

Cutting board

2-burner wok grate

Broiler pan

Dehydration rack set

Full-extension ball-bearing rack

Standard oven rack

Bake stone kit

Filler trim

Temperature probe

Signature red, black, or stainless steel control knobs

Rear caster covers

Front leg extension covers

Stainless steel kickplates

13 cm and 25 cm stainless steel risers, and 51 cm riser with shelf

Accessories available through an authorized dealer.



KNOB OPTIONS



TOP CONFIGURATION

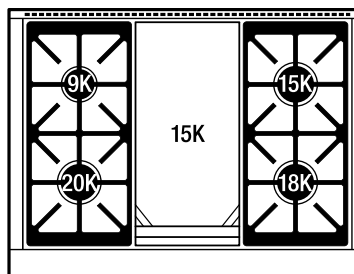

RANGETOP SPECIFICATIONS

- 1 - 9 MJ/h Burner
- 3 - 16 MJ/h Burner
- 1 - 15 MJ/h Teppanyaki

PRODUCT SPECIFICATIONS

Model	ICBDF36450G/S/P
Dimensions	911mmW x 929mmH x 749mmD
Oven 1 Overall Capacity	153 L
Electrical Supply	220-240 VAC; 50/60 Hz
Electrical Service	19 amp
Gas Inlet	Class B or Class D hose assembly

ELECTRICAL

GAS

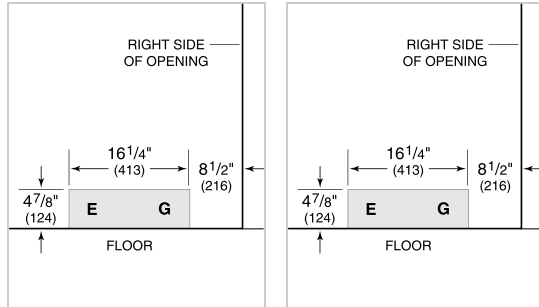

NOTE: Dimensions in parenthesis are in millimeters unless otherwise specified

DIMENSIONS

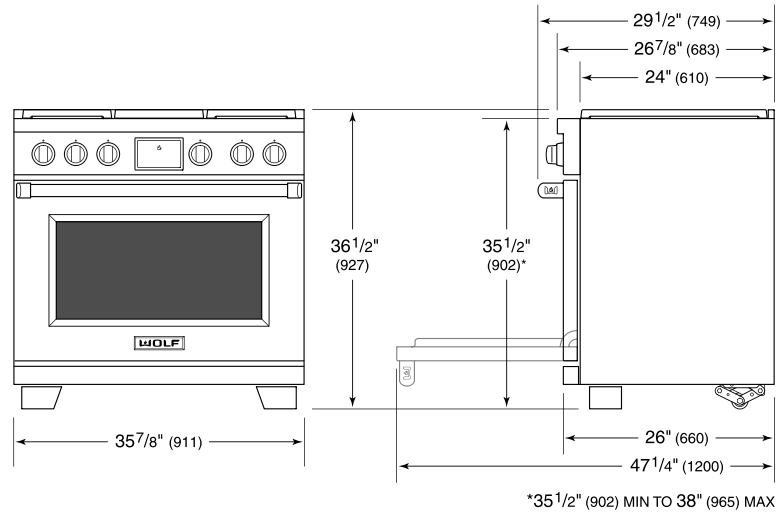

STANDARD INSTALLATION

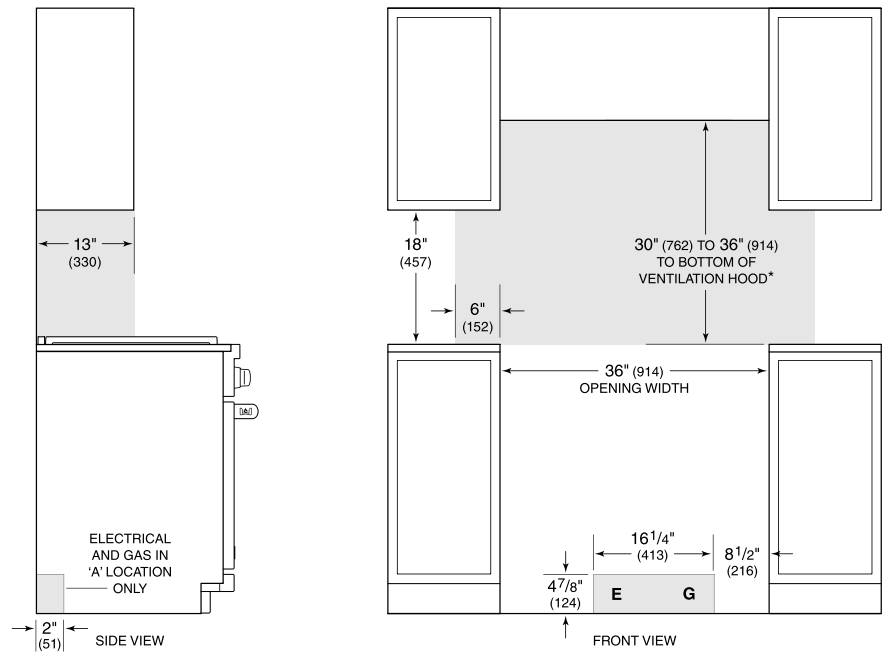

**Without ventilation hood, 36" (914) minimum clearance countertop to combustible materials, 44" (1118) for charbroiler.*

NOTE: Shaded area above countertop indicates minimum clearance to combustible surfaces, combustible materials cannot be located within this area.

For island installation, 12" (305) minimum clearance back of range to combustible rear wall above countertop.